

# Montagem de PCs

---



Christian César de Azevedo

# Material Necessário



- Gabinete com fonte de alimentação
- Processador
- Placa-mãe compatível com o processador
- Memória RAM compatível com o FSB da placa-mãe.
- Placa de vídeo
- Monitor de vídeo
- Disco rígido

# Material Necessário

---



- Unidade de CD-ROM
- Unidade de disquete (opcional)
- Teclado
- Mouse

# Passos para Montagem

---



## 1. Preparação do gabinete

- Abrir o gabinete
- Instalar os pés do gabinete
- Remover o chassi metálico utilizado na fixação da placa-mãe
- Instalar o acabamento metálico de acordo com a placa-mãe

# Passos para Montagem

---



## 2. Fixar a placa mãe na base

- ❑ Antes de fixar a placa, verifique em qual posição o conector do teclado coincide com o furo do gabinete.
- ❑ Instale os parafusos de fixação (parafuso hexagonal)
- ❑ Prenda a placa-mãe na base utilizando os parafusos cabeça redonda rosca fina.

# Passos para Montagem

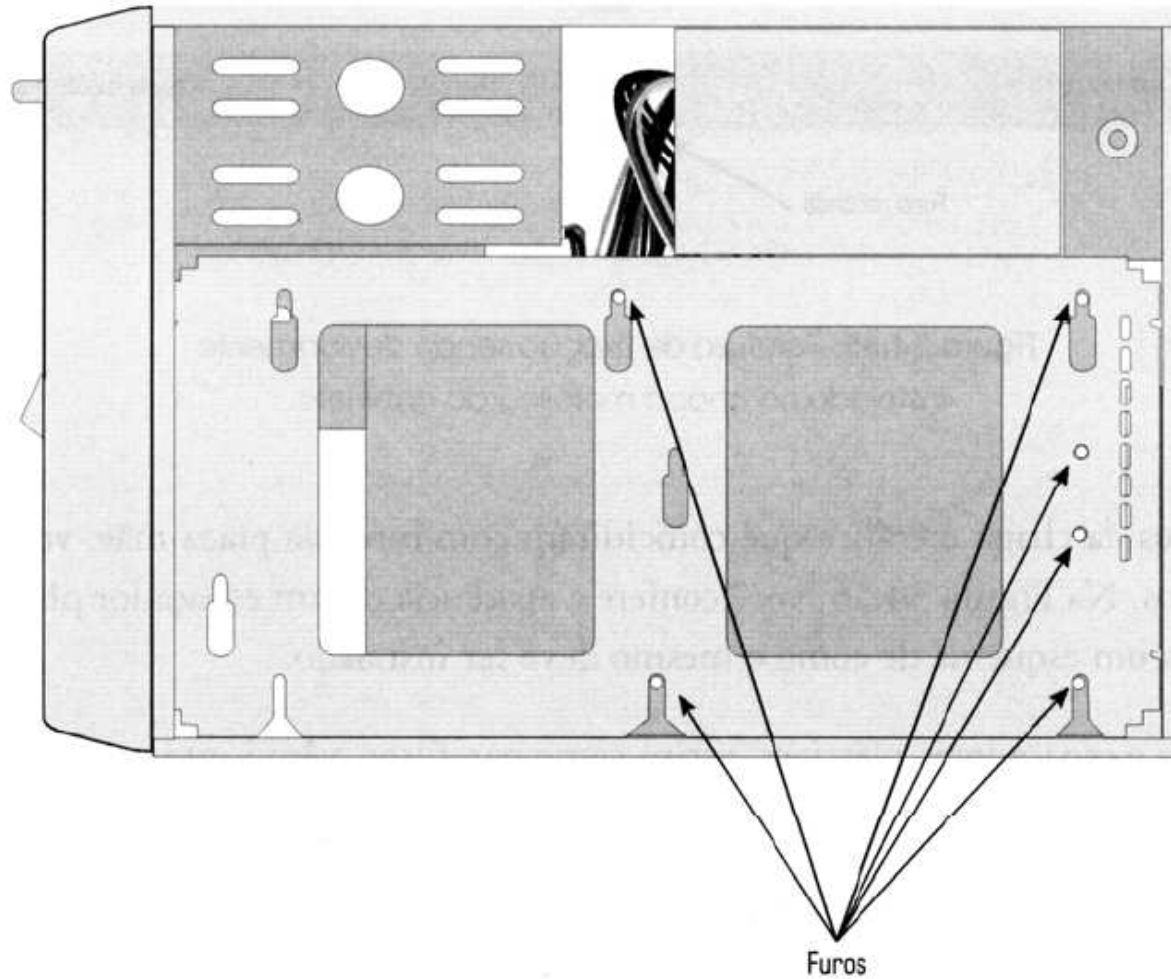

# Passos para Montagem

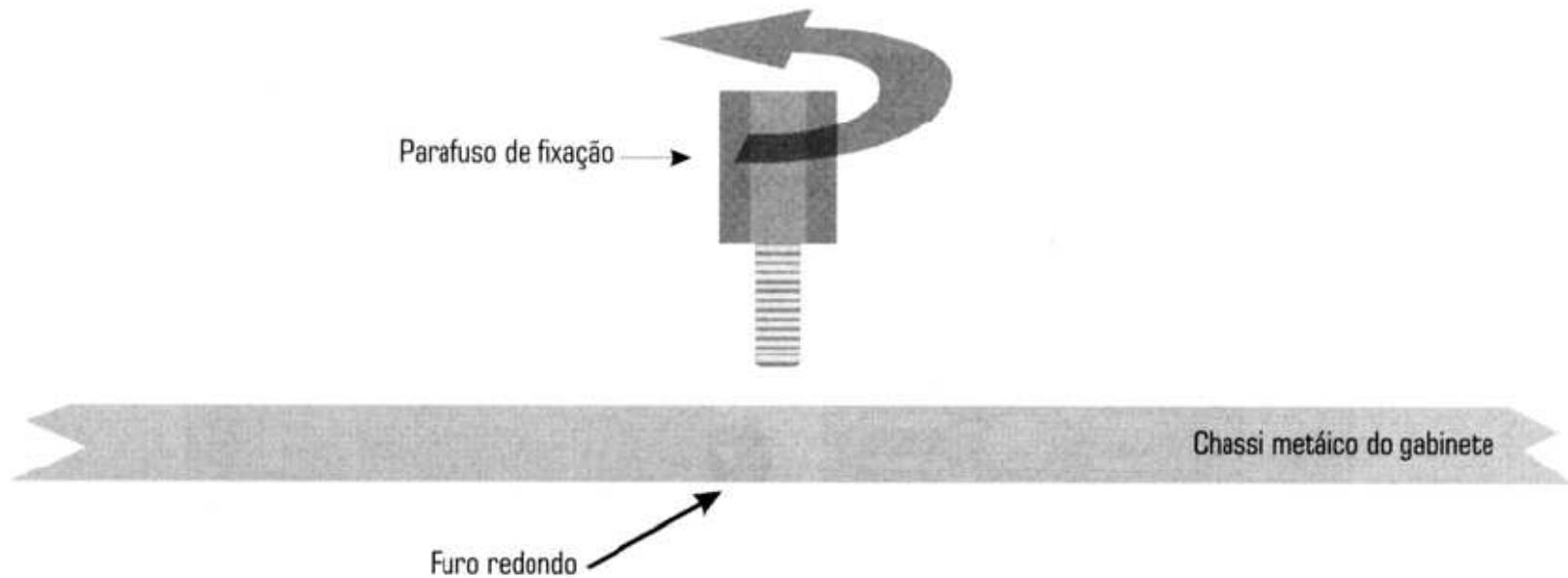

# Passos para Montagem

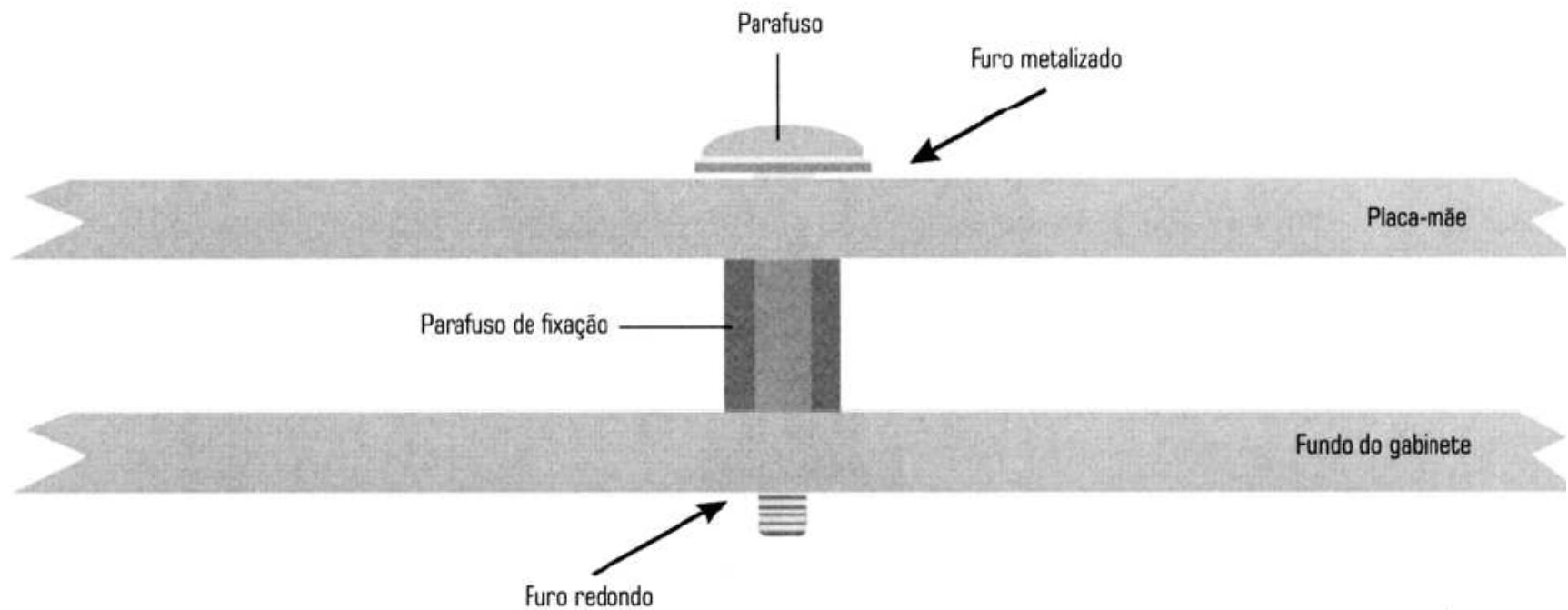



# Passos para Montagem

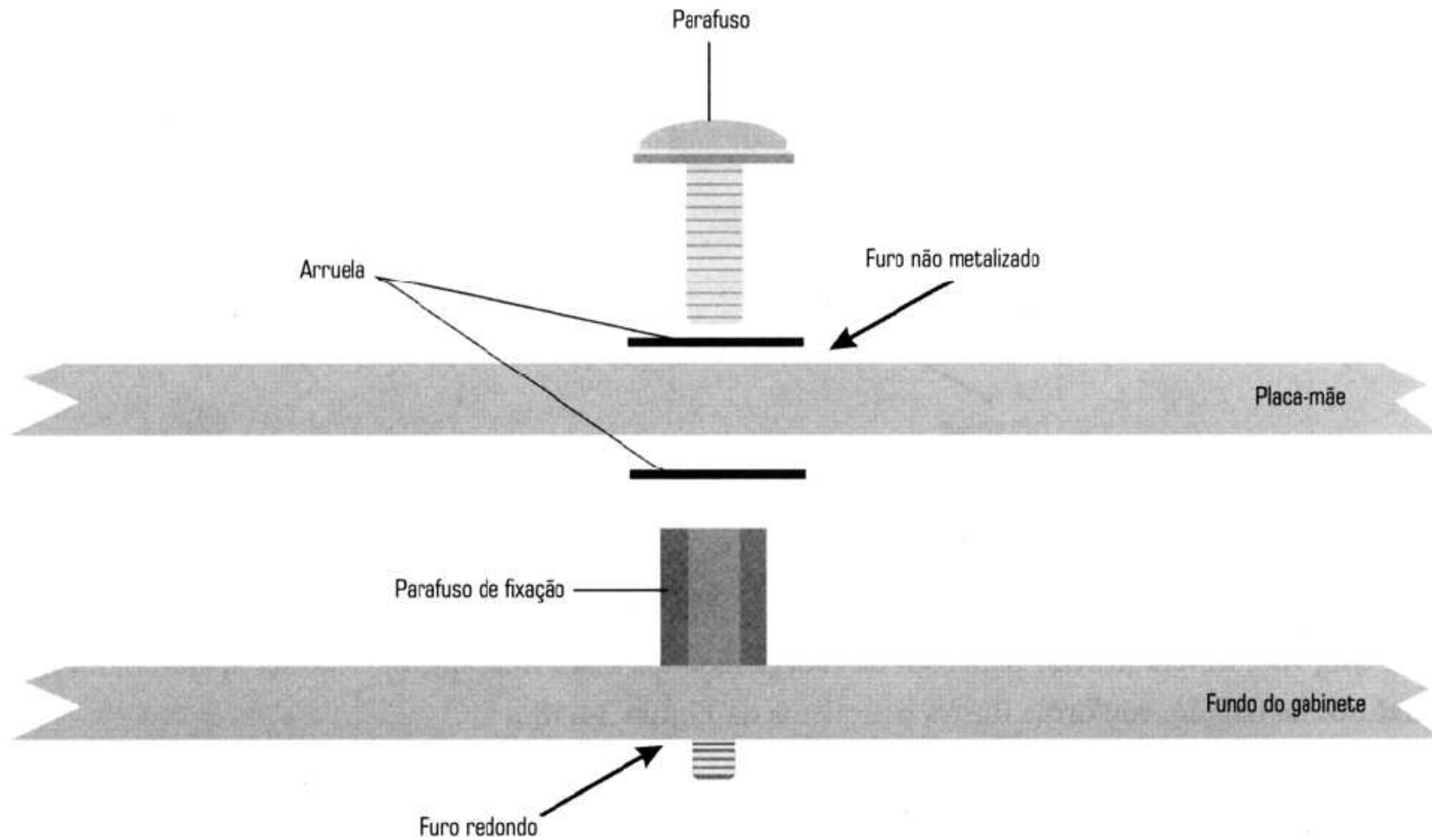

# Passos para Montagem



Detalhe do furo metalizado

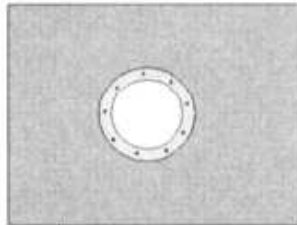

Detalhe do furo não metalizado

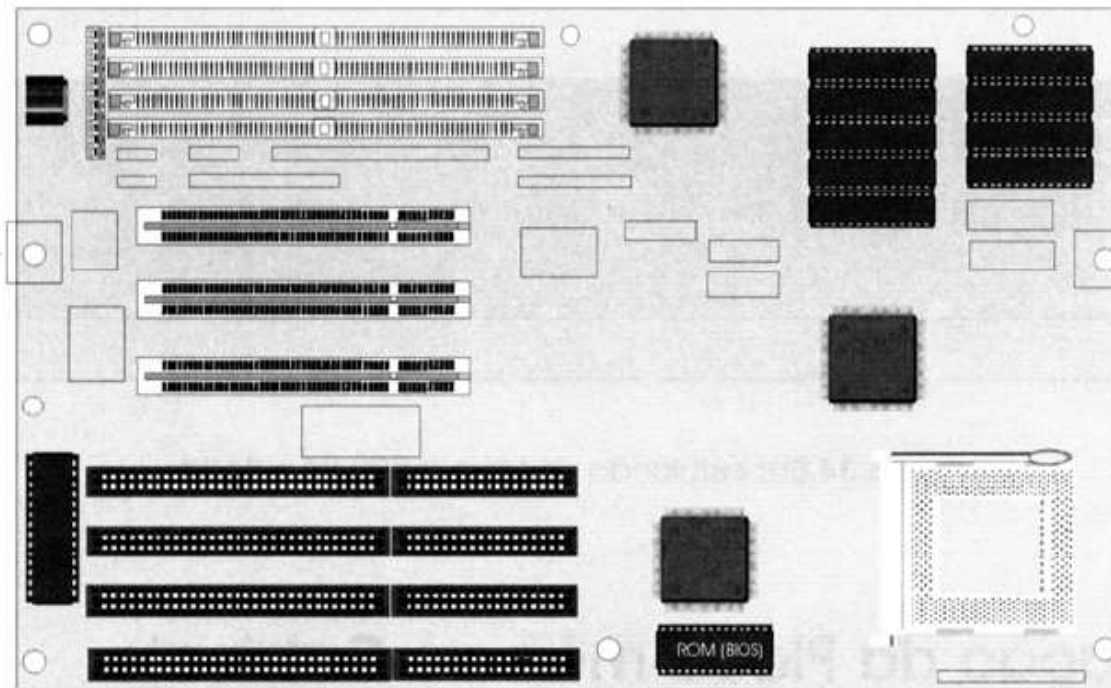
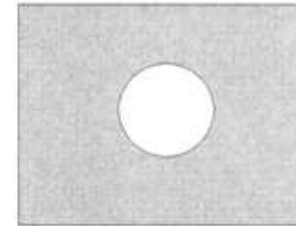

# Passos para Montagem



## 3. Jumpeamento da placa-mãe

- ❑ O primeiro jumper a conferir é o da bateria.  
**Para poder utilizar a placa-mãe este jumper deve estar na posição normal.**
- ❑ Outros jumpers da placa-mãe dependem do fabricante. Verifique o manual da placa-mãe.

# Passos para Montagem

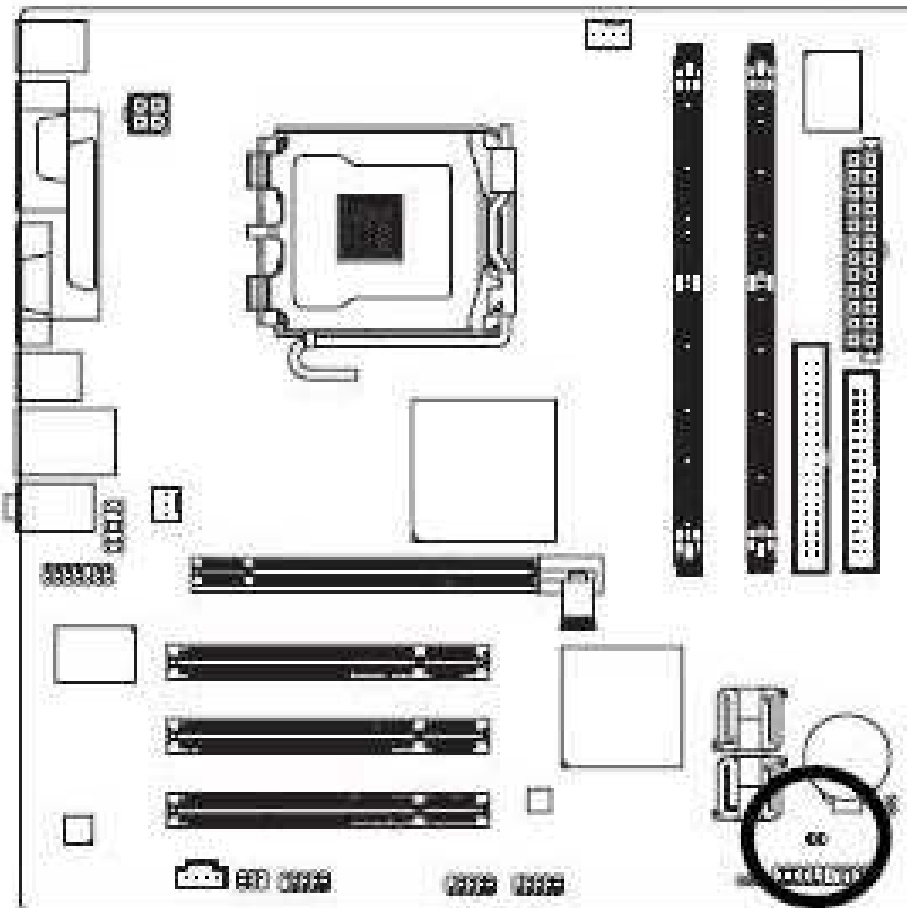

■ ■ Aberto: Normal

■ ■ Fechado: Limpa CMOS

# Passos para Montagem

---



4. Ligar o conector de alimentação da placa-mãe
  - ▣ No caso de placas-mãe que utilize fonte ATX12V existem dois conectores para instalar.

# Passos para Montagem

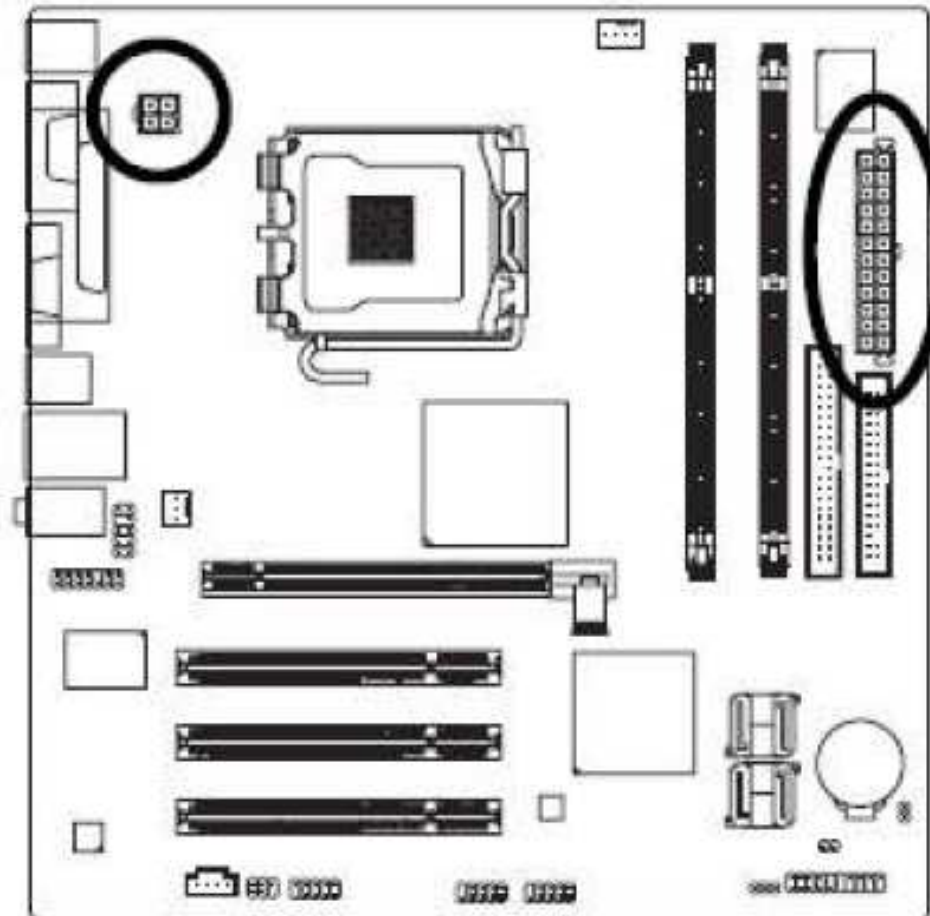

# Passos para Montagem



## 5. Instalação das memórias

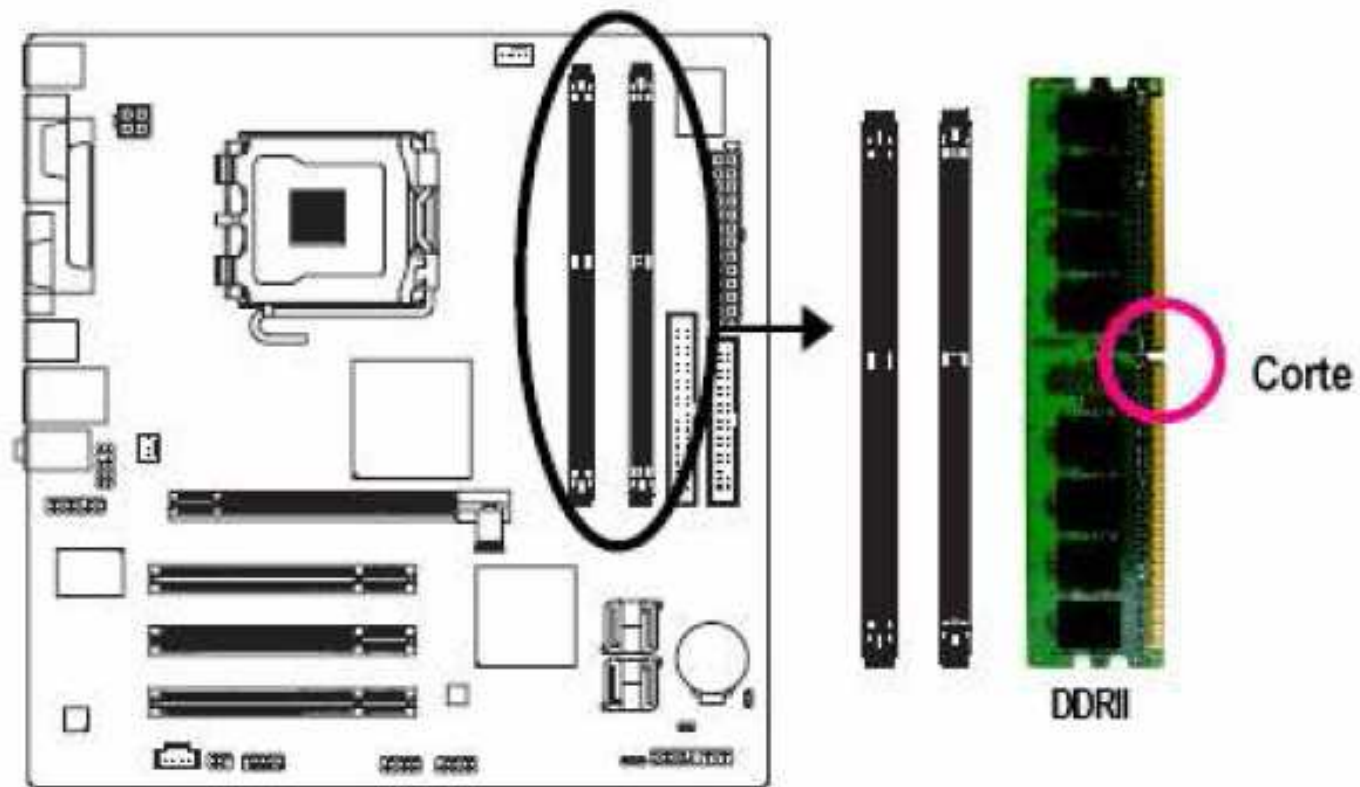

# Passos para Montagem



## 6. Instalação do processador

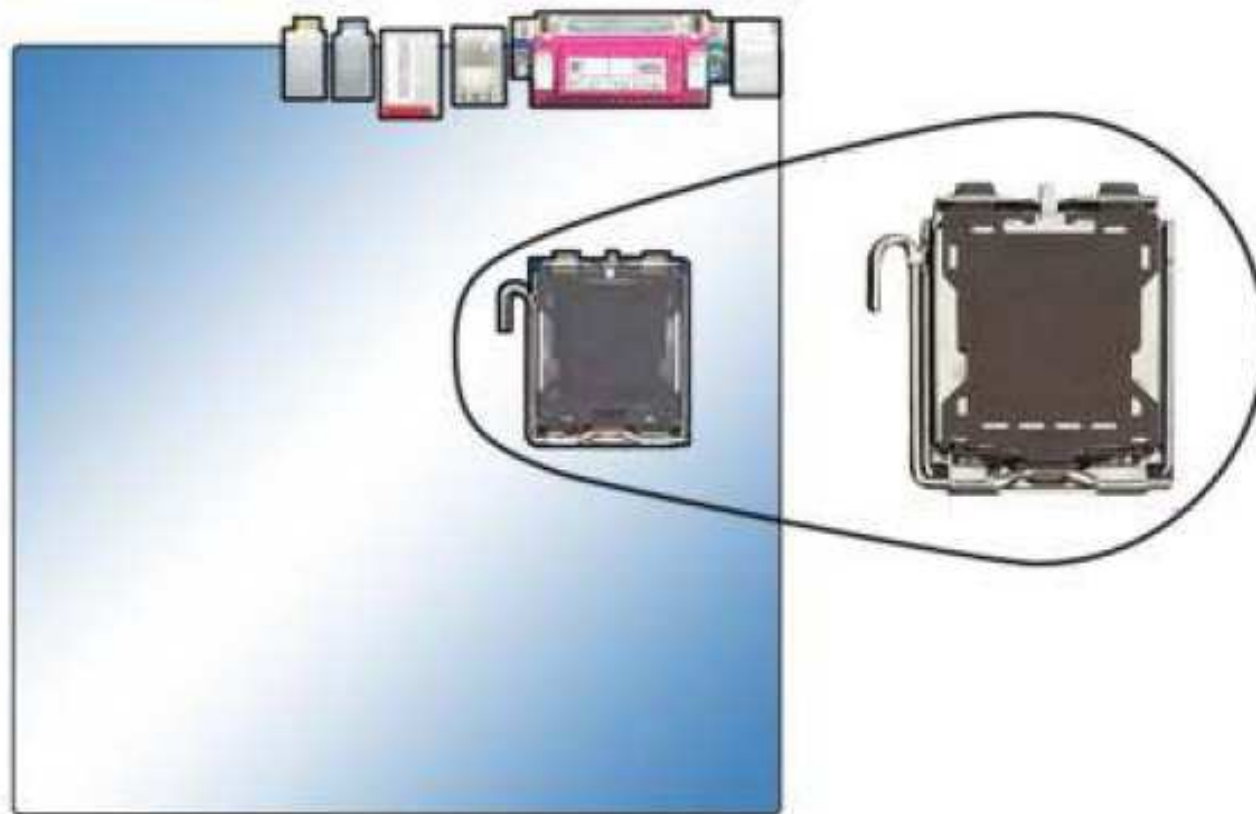



# Passos para Montagem



## 6. Instalação do processador



# Passos para Montagem



## 6. Instalação do processador

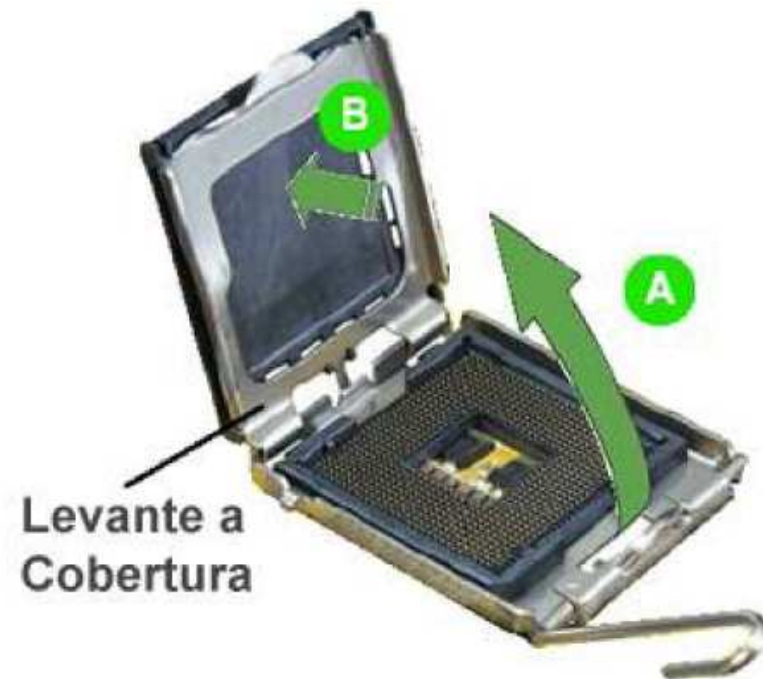
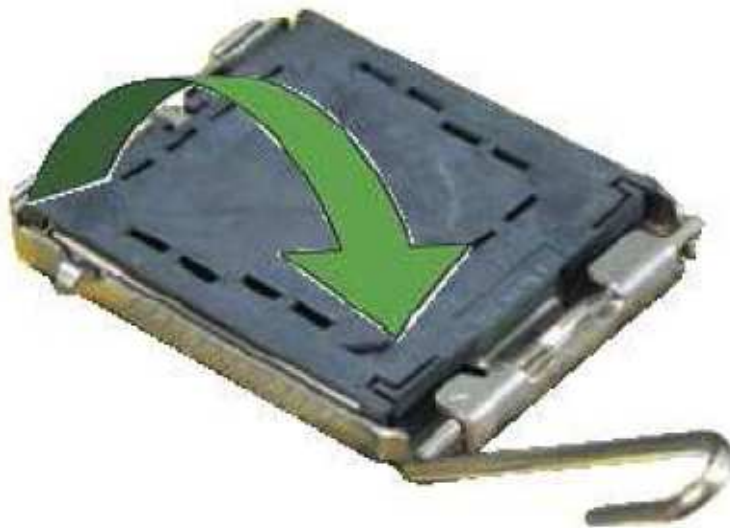

# Passos para Montagem



## 6. Instalação do processador



# Passos para Montagem



## 7. Instalação do cooler

- Aplique no processador uma fina camada de pasta térmica. **Seu uso não deve ser exagerado.**

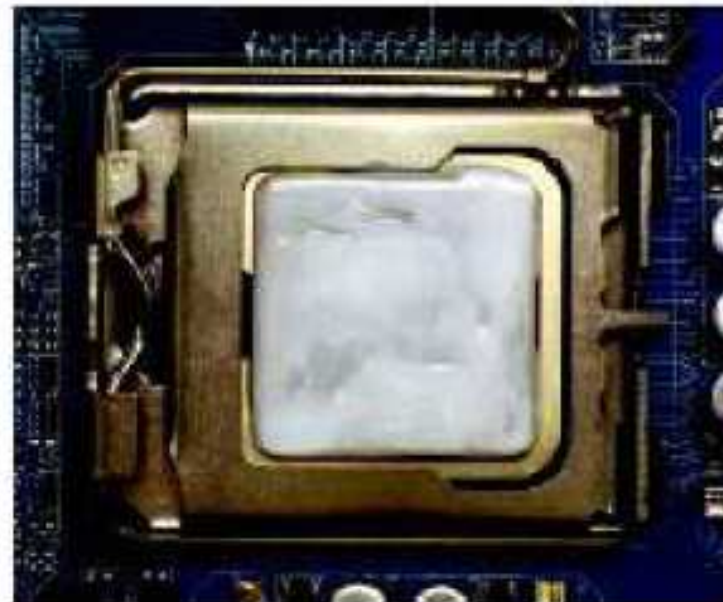

# Passos para Montagem

---



## 7. Instalação do cooler

- ❑ Instale o cooler na placa-mãe com o auxílio de uma chave de fenda.
- ❑ Instale o conector de alimentação do cooler na placa-mãe.

# Passos para Montagem

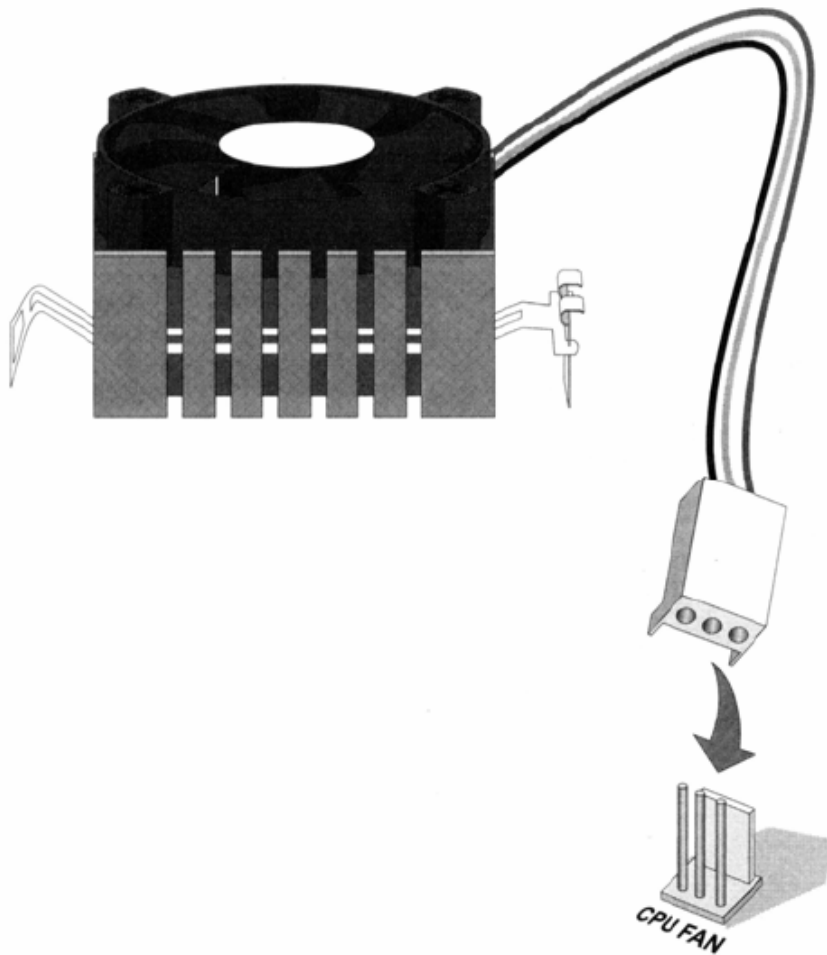

# Passos para Montagem

---



## 8. Instalação do painel frontal

- A ligação do painel frontal deve seguir o manual da placa-mãe



# Passos para Montagem

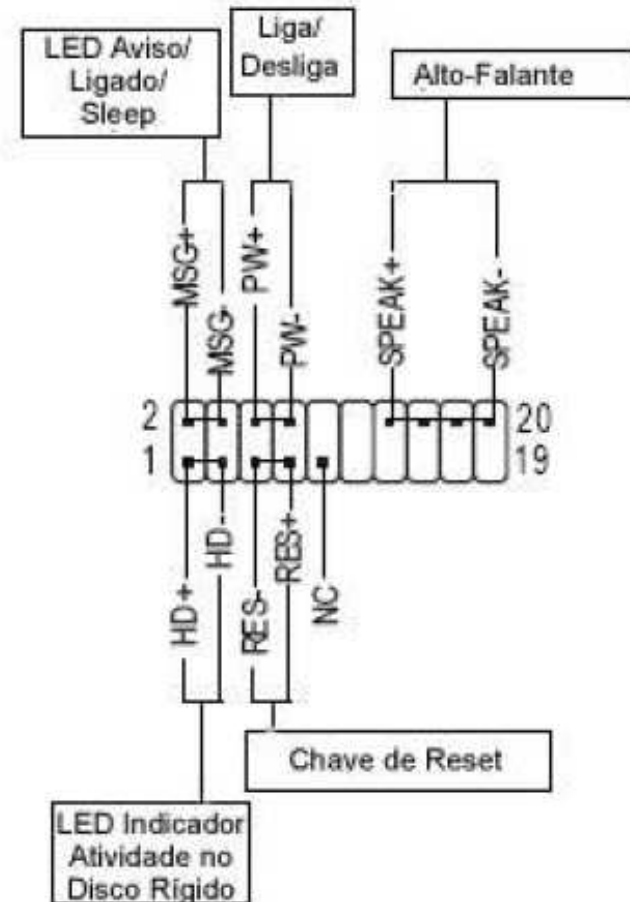
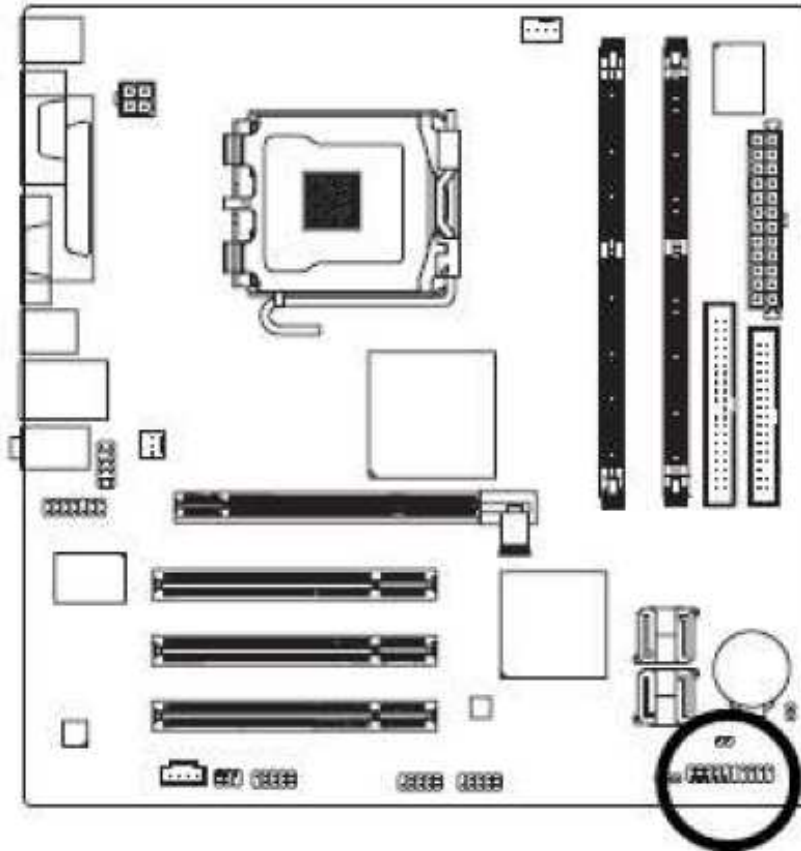



# Passos para Montagem

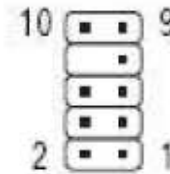
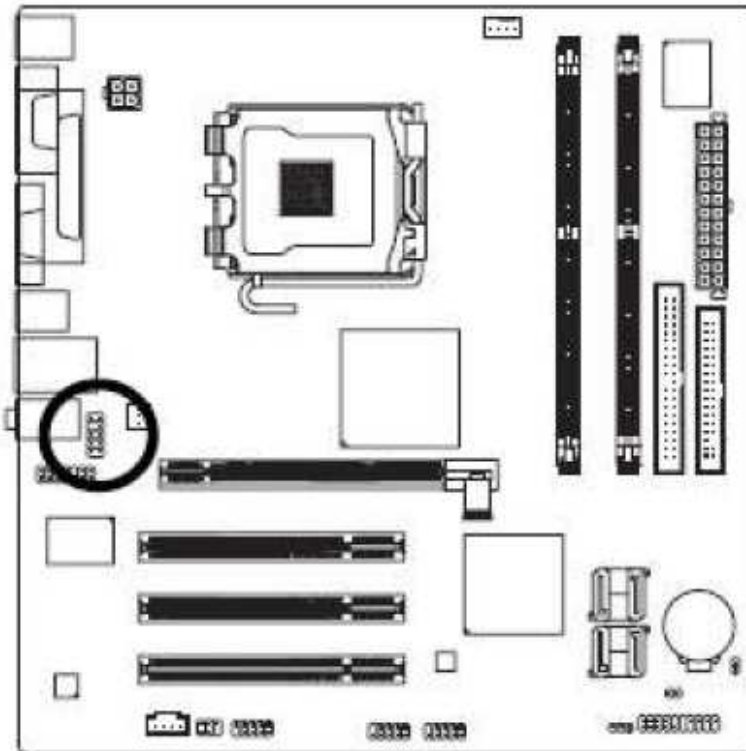

HD Audio:

| PINO | DEFINIÇÃO |
|------|-----------|
| 1    | MIC2_L    |
| 2    | TERRA     |
| 3    | MIC2_R    |
| 4    | -ACZ_DET  |
| 5    | Line2_R   |
| 6    | FSENSE1   |
| 7    | FAUOIO_JD |
| 8    | No Pin    |
| 9    | LINE2_L   |
| 10   | FSENSE2   |

AC'97 Audio:

| PINO | DEFINIÇÃO  |
|------|------------|
| 1    | MIC        |
| 2    | TERRA      |
| 3    | MICPower   |
| 4    | N/A        |
| 5    | LineOut(R) |
| 6    |            |
| 7    | N/A        |
| 8    | No Pin     |
| 9    | LineOut(L) |
| 10   | N/A        |

# Passos para Montagem

---



9. Teste. Para o PC ligar, ele precisa de:

- ❑ Placa-mãe
- ❑ Processador
- ❑ Memória RAM
- ❑ Alimentação
- ❑ Vídeo

# Passos para Montagem



## 10. Instalação dos conectores das interfaces.

- ❑ Serial: COM1 ou COM2
- ❑ Paralela: PRN, PT2, LPT1 ou LPT2
- ❑ Rede: LAN ou LAN network
- ❑ Porta USB
- ❑ Drive de disquete
- ❑ IDE
- ❑ SATA

# Passos para Montagem



## 10. Instalação dos conectores das interfaces.

Conector COM2

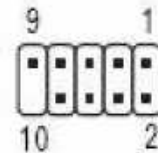
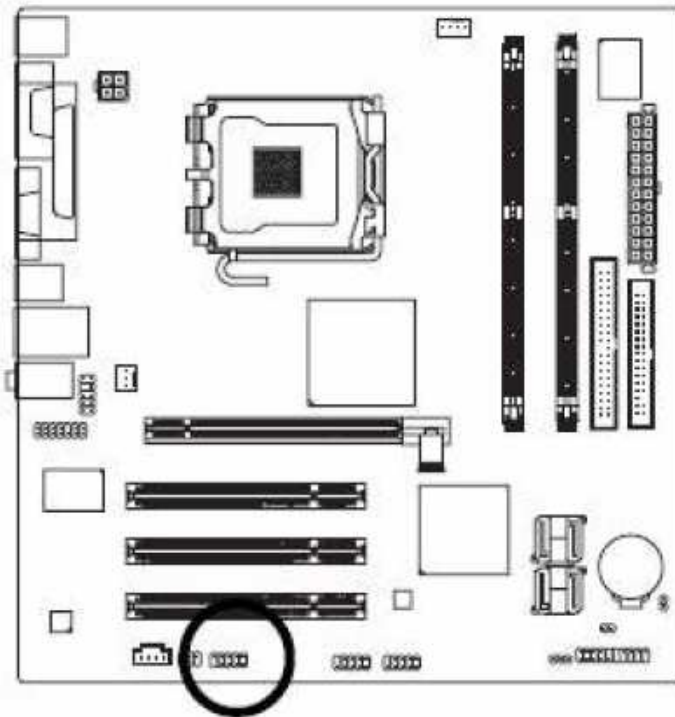

| PINO | DEFINIÇÃO |
|------|-----------|
| 1    | NDCDA/B-  |
| 2    | NSIN A/B  |
| 3    | NSOUT A/B |
| 4    | NDTRA/B-  |
| 5    | TERRA     |
| 6    | NDSRA/B-  |
| 7    | NRTSA/B-  |
| 8    | NCTSA/B-  |
| 9    | NRISA/B-  |
| 10   | No Pin    |

# Passos para Montagem



## 10. Instalação dos conectores das interfaces.

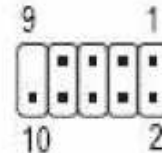
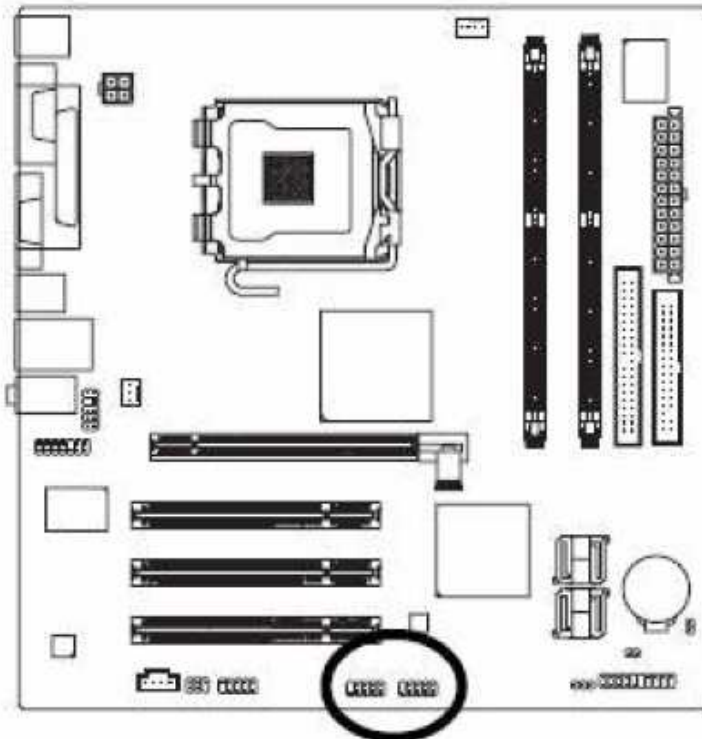

| PINO | DEFINIÇÃO            |
|------|----------------------|
| 1    | Power                |
| 2    | Power                |
| 3    | USB D <sub>x</sub> - |
| 4    | USB D <sub>y</sub> - |
| 5    | USB D <sub>x</sub> + |
| 6    | USB D <sub>y</sub> + |
| 7    | TERRA                |
| 8    | TERRA                |
| 9    | No Pin               |
| 10   | NC                   |

# Passos para Montagem



## 10. Instalação dos conectores das interfaces.

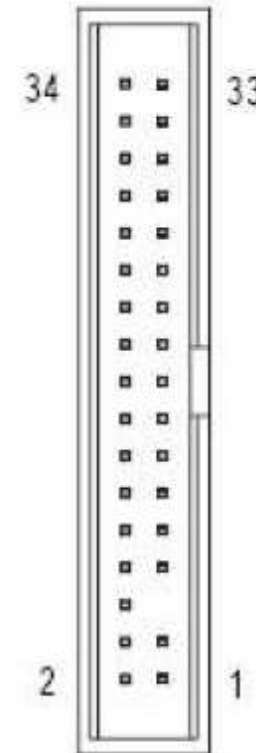
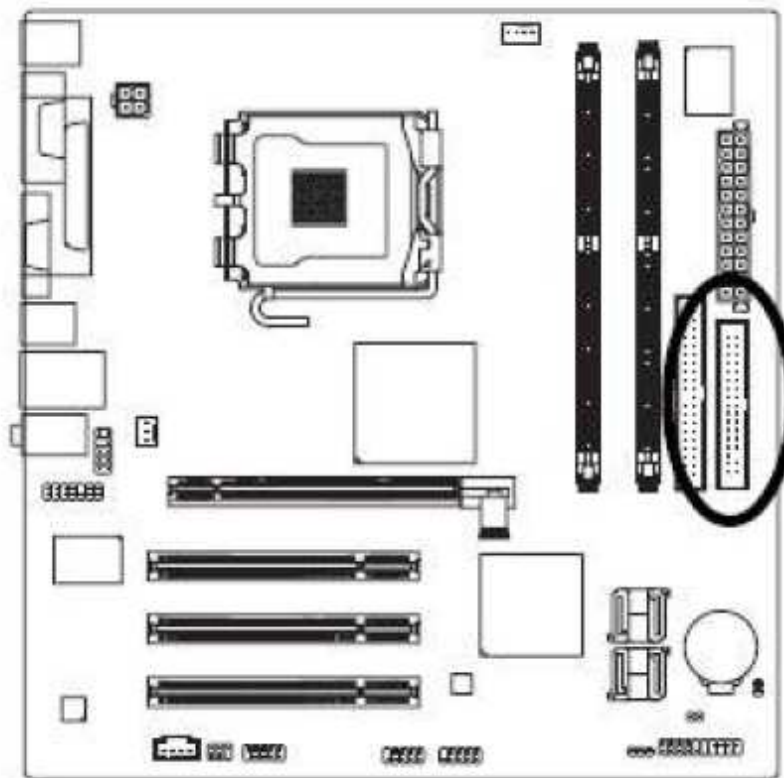

# Passos para Montagem



## 10. Instalação dos conectores das interfaces.

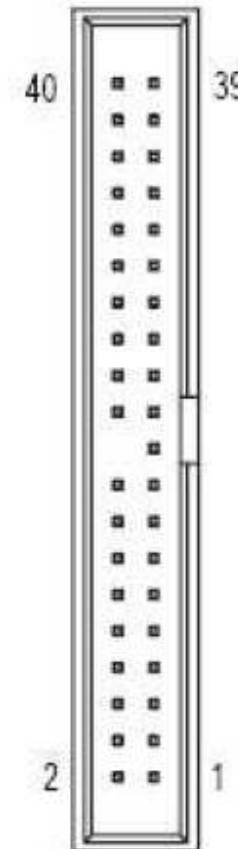
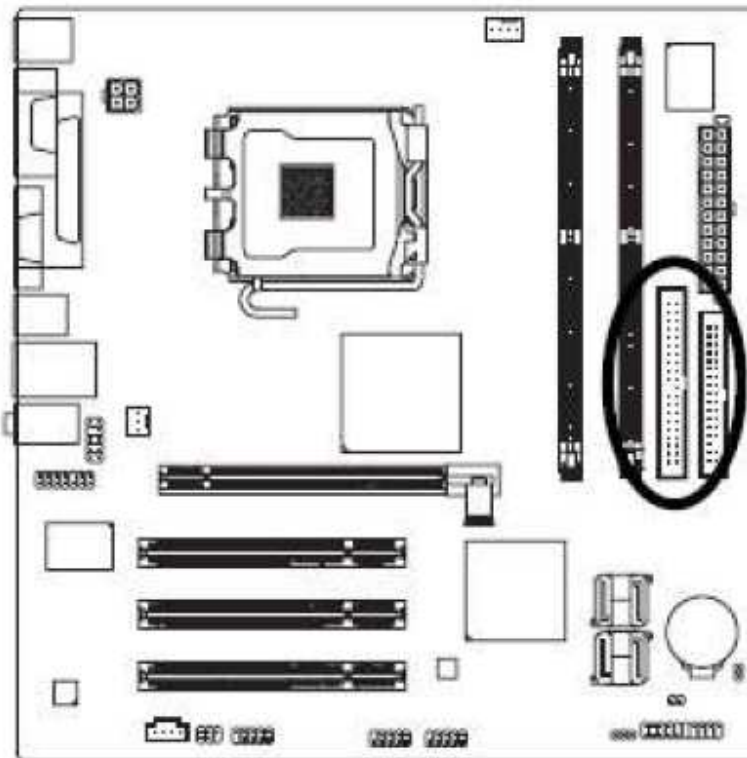

# Passos para Montagem



## 10. Instalação dos conectores das interfaces.

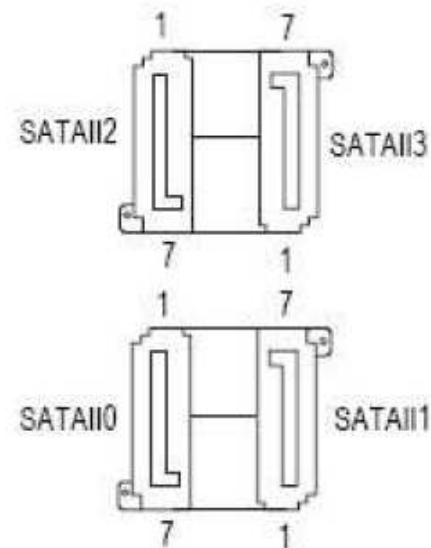
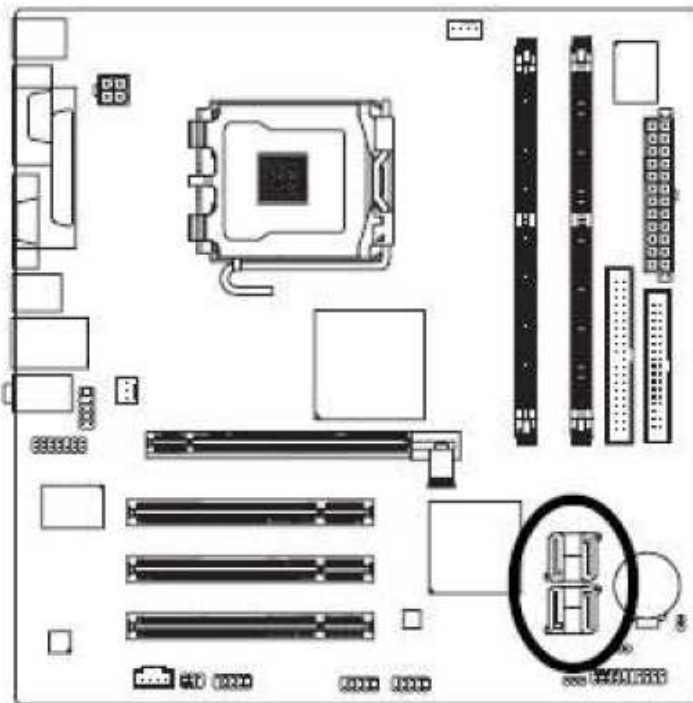

| PINO | DESCRIÇÃO |
|------|-----------|
| 1    | TERRA     |
| 2    | TXP       |
| 3    | TXN       |
| 4    | TERRA     |
| 5    | RXN       |
| 6    | RXP       |
| 7    | TERRA     |



# Passos para Montagem



## 11. Encaixando a base no gabinete

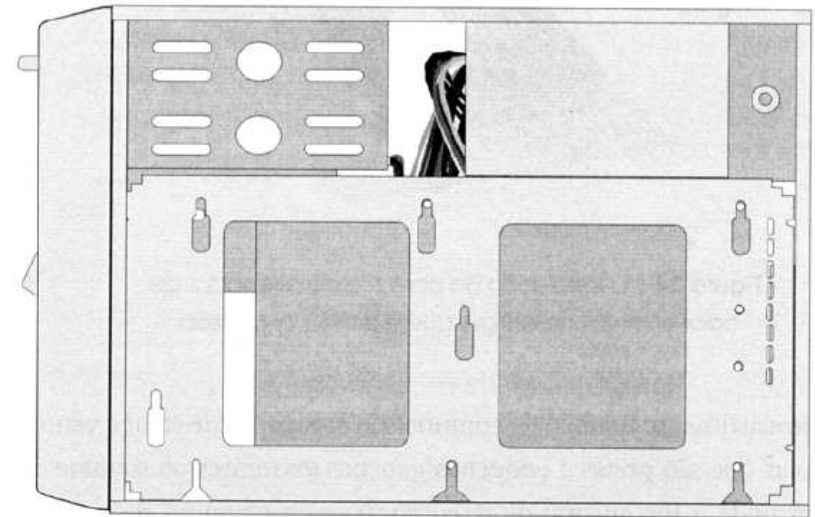
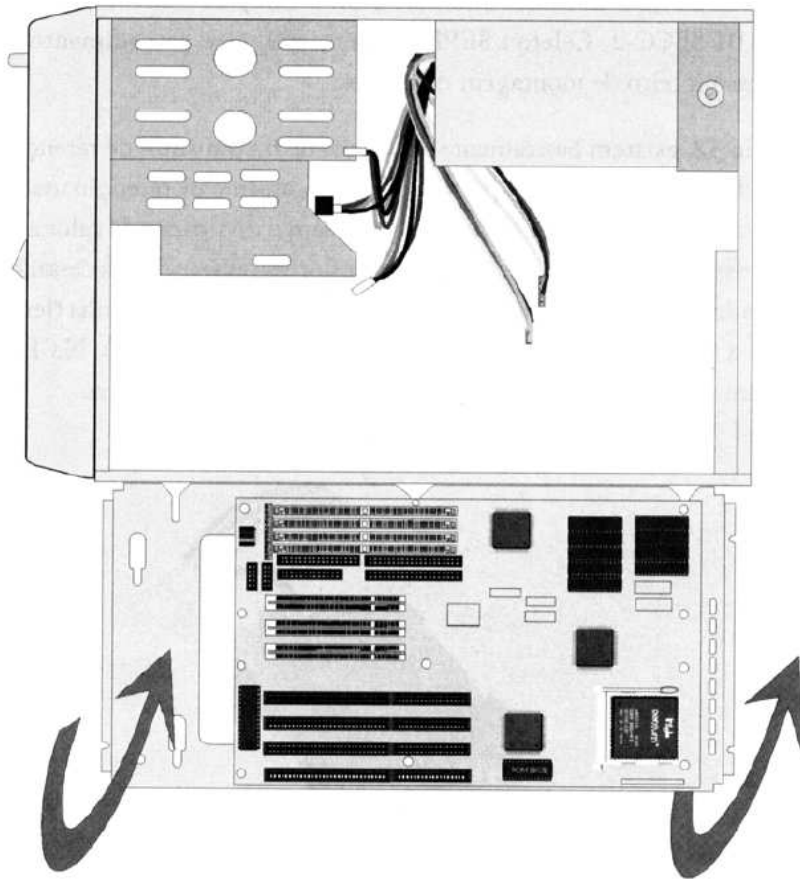

# Passos para Montagem

---



11. Aparafusando as interfaces

12. Instalação do disco rígido

13. Instalação do drive de disquete

# Passos para Montagem



## 14. Instalar o CD-ROM

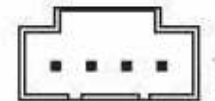
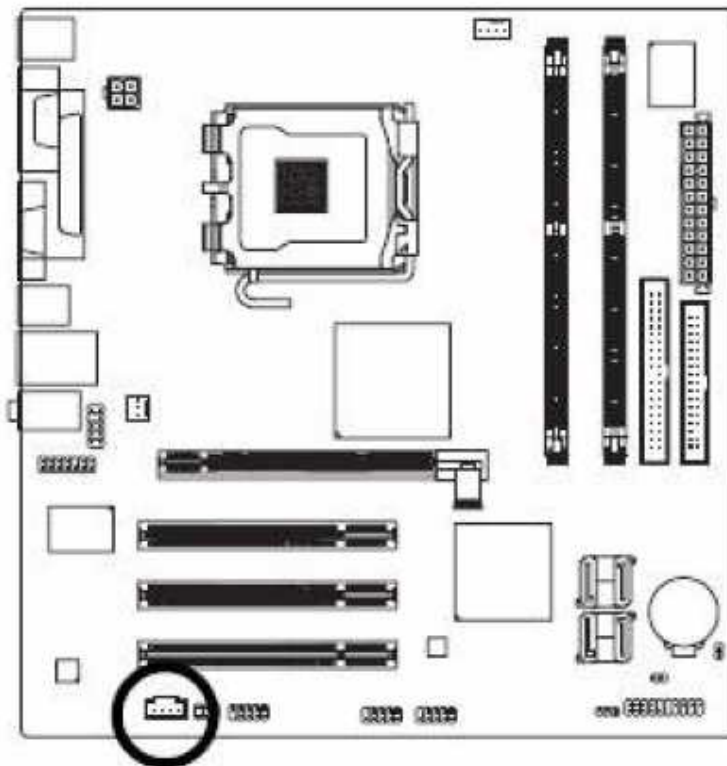

| PINO | DEFINIÇÃO |
|------|-----------|
| 1    | CD-L      |
| 2    | TERRA     |
| 3    | TERRA     |
| 4    | CD-R      |

# Passos para Montagem

---



## 15. Verificação Pós-montagem

- ❑ Conectores da fonte
- ❑ Cabos flat
- ❑ Memória
- ❑ Conectores de interfaces
- ❑ Demais placas

# Passos para Montagem

---



## 16. Setup

- ❑ Acertar data, hora e tipo de drive de disquete
- ❑ Sequencia de boot: configure A: C:
- ❑ Reconhecimento do disco rígido
- ❑ Configuração do multiplicador
- ❑ Salvar as opções e sair do setup.

# Passos para Montagem

---



## 17. Preparando o disco rígido

- ❑ Usar um disco de boot para acessar o FDisk;
- ❑ Criar partições
- ❑ Reiniciar o PC e formatar as partições recém-criadas.

# Passos para Montagem

---



18. Instale e configure o sistema operacional
  
19. Organização interna

# Perguntas?

---

